



# Accent, (DVS / DVL) Backing Plate

See Part Numbers Below

## Compatibility:

- DVS Insert with Large Backing Plate (95100061) and Doors (see part numbers below)
- DVL Insert with Large Backing Plate (95100066) and Doors (see part numbers below)

## Part Numbers

|                  |          |                  |          |
|------------------|----------|------------------|----------|
| DVS Black        | 96500931 | DVL Black        | 96500941 |
| DVS Artisan      | 96500932 | DVL Artisan      | 96500942 |
| DVS Bronze       | 96500933 | DVL Bronze       | 96500943 |
| DVS Nickel       | 96500934 | DVL Nickel       | 96500944 |
| DVS Copper       | 96500935 | DVL Copper       | 96500945 |
| DVS Tree of Life | 96500936 | DVL Tree of Life | 96500946 |
| DVS Bungalow     | 96500937 | DVL Bungalow     | 96500947 |

## Installation

**WARNING:** The magnets are very strong and may scratch the paint on the backing plate if the accent is re-positioned while in place. Take care while re-positioning the accent. Keep the magnets away from children.

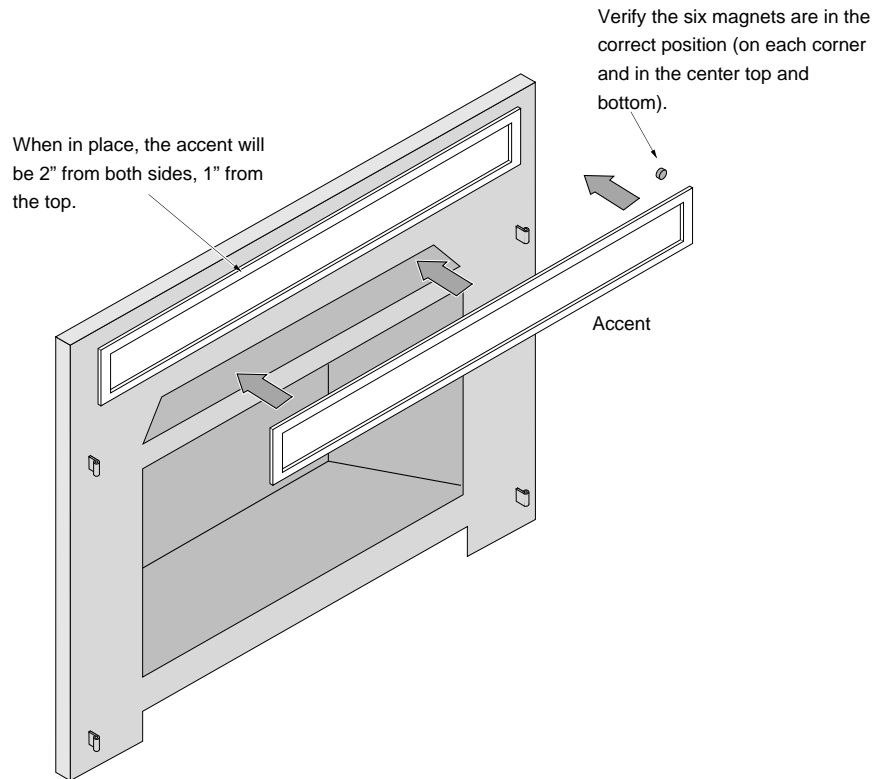

### Plated Surfaces (Bronze & Nickel)

Use denatured alcohol and a soft cloth to clean plated surfaces. Marks left on the surface may damage the face.

### Copper-Plated Surfaces

See the instructions included with the onlay kit for cleaning with citric acid.

